

WICSLIDE 160

Lifting/sliding systems



» Aluminium lifting/sliding systems

The WICSLIDE 160 lifting/sliding systems is ideal for all projects which require large sizes and outstanding thermal and acoustic performance. This lifting/sliding systems is characterised by sober lines, ergonomics, quality, security, ease of operation and simplified manufacture.

Aesthetic research today brings you a harmonious and sophisticated lifting/sliding system; the pure, sober lines of the minimalist design accentuate its large sizes. The locking parts, perfectly integrated into the fixed frame, present no sharp edges in the open position.



WICSLIDE 160 lifting/sliding systems

- Description and performance

Construction principle

Single track

High insulation

Connection with WICLINE 65/75 and WICSTYLE 65/75

Closure systems, equipment

Opening types

4-5

6

6

7

8

9

10



2 |



3 |



4 |

1 | Lucie Aubrac School - Nanterre (92)

Architects: Dietmar Feichtinger Architectes, Paris (75) - Company: Plastalu, Ouges (21)
Photos: David Boureau

2 | Restaurant L'Océan

Architect: Bureau & d'Achon - Company: GH - Photo: Xavier Benony

3 | Lucie Aubrac School - Nanterre (92)

Architects: Dietmar Feichtinger Architectes, Paris (75) - Company: Plastalu, Ouges (21)
Photos: David Boureau

4 | Restaurant Tetedoie, Lyon

Architect: Agence BAC - Company: Thivillon - Photo: Studio Erick Saillet

WICSLIDE 160



Technical characteristics

- Sash with two to five locking points according to the height of the sash
- Meeting points between leaves sealed by means of a screw-fitted hooking profile with coextruded gaskets
- Patented system at the top of the sash ensures water tightness in any position
- Stainless steel track provides increased durability
- Excellent burglar resistance, RC2 and RC2N
- Handles fitted on a 10 mm square drive.
- High thermal insulation version available with insulating profiles inserted

Outstanding performance

Maximum sizes

- W 3,240 mm - H 3,400 mm per sash, with a maximum weight per sash of 400 kg

Acoustic properties

- **Rw 47 Db** acoustic test passed for specific project in Lebanon
- Wicslide 160 lift & slide system 1 fixed frame + 1 sash thermally broken system, double glazing external glass
- Frame dimensions W 2640 x H 2798 mm

Thermal properties

- Uw: 1.6 W/m².K, glazing Ug: 1.2 W/m².K (double glazing)
- Uw: < 1.1 W/m².K, glazing Ug: 0.6 W/m².K (triple glazing)
- Frame dimensions W 4,500 mm x H 2,300 mm

Weather performance

- Air: Class 4 - Water: E750A - Wind: Class C3 (Dimensions of two-leaf frame W 4,000 mm x H 2,500 mm)

Burglar resistance

Justificatif Caractéristiques anti-effraction																																																																																																																																																																																														
Rapport d'essai No. 11-003493-PRO1 (PB-A01-05-11-01)																																																																																																																																																																																														
Client	Hydro Building Systems GmbH Söllinger Str. 79 89077 Ulm Allemagne	<table border="1"> <tr><td>Relevé</td><td>0204 1007 - 2012</td></tr> <tr><td>Relevé</td><td>0204 1008 - 2012</td></tr> <tr><td>Relevé</td><td>0204 1009 - 2012</td></tr> <tr><td>Relevé</td><td>0204 1010 - 2012</td></tr> <tr><td>Relevé</td><td>0204 1011 - 2012</td></tr> <tr><td>Relevé</td><td>0204 1012 - 2012</td></tr> <tr><td>Relevé</td><td>0204 1013 - 2012</td></tr> <tr><td>Relevé</td><td>0204 1014 - 2012</td></tr> <tr><td>Relevé</td><td>0204 1015 - 2012</td></tr> <tr><td>Relevé</td><td>0204 1016 - 2012</td></tr> <tr><td>Relevé</td><td>0204 1017 - 2012</td></tr> <tr><td>Relevé</td><td>0204 1018 - 2012</td></tr> <tr><td>Relevé</td><td>0204 1019 - 2012</td></tr> <tr><td>Relevé</td><td>0204 1020 - 2012</td></tr> <tr><td>Relevé</td><td>0204 1021 - 2012</td></tr> <tr><td>Relevé</td><td>0204 1022 - 2012</td></tr> <tr><td>Relevé</td><td>0204 1023 - 2012</td></tr> <tr><td>Relevé</td><td>0204 1024 - 2012</td></tr> <tr><td>Relevé</td><td>0204 1025 - 2012</td></tr> <tr><td>Relevé</td><td>0204 1026 - 2012</td></tr> <tr><td>Relevé</td><td>0204 1027 - 2012</td></tr> <tr><td>Relevé</td><td>0204 1028 - 2012</td></tr> <tr><td>Relevé</td><td>0204 1029 - 2012</td></tr> <tr><td>Relevé</td><td>0204 1030 - 2012</td></tr> <tr><td>Relevé</td><td>0204 1031 - 2012</td></tr> <tr><td>Relevé</td><td>0204 1032 - 2012</td></tr> <tr><td>Relevé</td><td>0204 1033 - 2012</td></tr> <tr><td>Relevé</td><td>0204 1034 - 2012</td></tr> <tr><td>Relevé</td><td>0204 1035 - 2012</td></tr> <tr><td>Relevé</td><td>0204 1036 - 2012</td></tr> <tr><td>Relevé</td><td>0204 1037 - 2012</td></tr> <tr><td>Relevé</td><td>0204 1038 - 2012</td></tr> <tr><td>Relevé</td><td>0204 1039 - 2012</td></tr> <tr><td>Relevé</td><td>0204 1040 - 2012</td></tr> <tr><td>Relevé</td><td>0204 1041 - 2012</td></tr> <tr><td>Relevé</td><td>0204 1042 - 2012</td></tr> <tr><td>Relevé</td><td>0204 1043 - 2012</td></tr> <tr><td>Relevé</td><td>0204 1044 - 2012</td></tr> <tr><td>Relevé</td><td>0204 1045 - 2012</td></tr> <tr><td>Relevé</td><td>0204 1046 - 2012</td></tr> <tr><td>Relevé</td><td>0204 1047 - 2012</td></tr> <tr><td>Relevé</td><td>0204 1048 - 2012</td></tr> <tr><td>Relevé</td><td>0204 1049 - 2012</td></tr> <tr><td>Relevé</td><td>0204 1050 - 2012</td></tr> <tr><td>Relevé</td><td>0204 1051 - 2012</td></tr> <tr><td>Relevé</td><td>0204 1052 - 2012</td></tr> <tr><td>Relevé</td><td>0204 1053 - 2012</td></tr> <tr><td>Relevé</td><td>0204 1054 - 2012</td></tr> <tr><td>Relevé</td><td>0204 1055 - 2012</td></tr> <tr><td>Relevé</td><td>0204 1056 - 2012</td></tr> <tr><td>Relevé</td><td>0204 1057 - 2012</td></tr> <tr><td>Relevé</td><td>0204 1058 - 2012</td></tr> <tr><td>Relevé</td><td>0204 1059 - 2012</td></tr> <tr><td>Relevé</td><td>0204 1060 - 2012</td></tr> <tr><td>Relevé</td><td>0204 1061 - 2012</td></tr> <tr><td>Relevé</td><td>0204 1062 - 2012</td></tr> <tr><td>Relevé</td><td>0204 1063 - 2012</td></tr> <tr><td>Relevé</td><td>0204 1064 - 2012</td></tr> <tr><td>Relevé</td><td>0204 1065 - 2012</td></tr> <tr><td>Relevé</td><td>0204 1066 - 2012</td></tr> <tr><td>Relevé</td><td>0204 1067 - 2012</td></tr> <tr><td>Relevé</td><td>0204 1068 - 2012</td></tr> <tr><td>Relevé</td><td>0204 1069 - 2012</td></tr> <tr><td>Relevé</td><td>0204 1070 - 2012</td></tr> <tr><td>Relevé</td><td>0204 1071 - 2012</td></tr> <tr><td>Relevé</td><td>0204 1072 - 2012</td></tr> <tr><td>Relevé</td><td>0204 1073 - 2012</td></tr> <tr><td>Relevé</td><td>0204 1074 - 2012</td></tr> <tr><td>Relevé</td><td>0204 1075 - 2012</td></tr> <tr><td>Relevé</td><td>0204 1076 - 2012</td></tr> <tr><td>Relevé</td><td>0204 1077 - 2012</td></tr> <tr><td>Relevé</td><td>0204 1078 - 2012</td></tr> <tr><td>Relevé</td><td>0204 1079 - 2012</td></tr> <tr><td>Relevé</td><td>0204 1080 - 2012</td></tr> <tr><td>Relevé</td><td>0204 1081 - 2012</td></tr> <tr><td>Relevé</td><td>0204 1082 - 2012</td></tr> <tr><td>Relevé</td><td>0204 1083 - 2012</td></tr> <tr><td>Relevé</td><td>0204 1084 - 2012</td></tr> <tr><td>Relevé</td><td>0204 1085 - 2012</td></tr> <tr><td>Relevé</td><td>0204 1086 - 2012</td></tr> <tr><td>Relevé</td><td>0204 1087 - 2012</td></tr> <tr><td>Relevé</td><td>0204 1088 - 2012</td></tr> <tr><td>Relevé</td><td>0204 1089 - 2012</td></tr> <tr><td>Relevé</td><td>0204 1090 - 2012</td></tr> <tr><td>Relevé</td><td>0204 1091 - 2012</td></tr> <tr><td>Relevé</td><td>0204 1092 - 2012</td></tr> <tr><td>Relevé</td><td>0204 1093 - 2012</td></tr> <tr><td>Relevé</td><td>0204 1094 - 2012</td></tr> <tr><td>Relevé</td><td>0204 1095 - 2012</td></tr> <tr><td>Relevé</td><td>0204 1096 - 2012</td></tr> <tr><td>Relevé</td><td>0204 1097 - 2012</td></tr> <tr><td>Relevé</td><td>0204 1098 - 2012</td></tr> <tr><td>Relevé</td><td>0204 1099 - 2012</td></tr> <tr><td>Relevé</td><td>0204 1100 - 2012</td></tr> </table>	Relevé	0204 1007 - 2012	Relevé	0204 1008 - 2012	Relevé	0204 1009 - 2012	Relevé	0204 1010 - 2012	Relevé	0204 1011 - 2012	Relevé	0204 1012 - 2012	Relevé	0204 1013 - 2012	Relevé	0204 1014 - 2012	Relevé	0204 1015 - 2012	Relevé	0204 1016 - 2012	Relevé	0204 1017 - 2012	Relevé	0204 1018 - 2012	Relevé	0204 1019 - 2012	Relevé	0204 1020 - 2012	Relevé	0204 1021 - 2012	Relevé	0204 1022 - 2012	Relevé	0204 1023 - 2012	Relevé	0204 1024 - 2012	Relevé	0204 1025 - 2012	Relevé	0204 1026 - 2012	Relevé	0204 1027 - 2012	Relevé	0204 1028 - 2012	Relevé	0204 1029 - 2012	Relevé	0204 1030 - 2012	Relevé	0204 1031 - 2012	Relevé	0204 1032 - 2012	Relevé	0204 1033 - 2012	Relevé	0204 1034 - 2012	Relevé	0204 1035 - 2012	Relevé	0204 1036 - 2012	Relevé	0204 1037 - 2012	Relevé	0204 1038 - 2012	Relevé	0204 1039 - 2012	Relevé	0204 1040 - 2012	Relevé	0204 1041 - 2012	Relevé	0204 1042 - 2012	Relevé	0204 1043 - 2012	Relevé	0204 1044 - 2012	Relevé	0204 1045 - 2012	Relevé	0204 1046 - 2012	Relevé	0204 1047 - 2012	Relevé	0204 1048 - 2012	Relevé	0204 1049 - 2012	Relevé	0204 1050 - 2012	Relevé	0204 1051 - 2012	Relevé	0204 1052 - 2012	Relevé	0204 1053 - 2012	Relevé	0204 1054 - 2012	Relevé	0204 1055 - 2012	Relevé	0204 1056 - 2012	Relevé	0204 1057 - 2012	Relevé	0204 1058 - 2012	Relevé	0204 1059 - 2012	Relevé	0204 1060 - 2012	Relevé	0204 1061 - 2012	Relevé	0204 1062 - 2012	Relevé	0204 1063 - 2012	Relevé	0204 1064 - 2012	Relevé	0204 1065 - 2012	Relevé	0204 1066 - 2012	Relevé	0204 1067 - 2012	Relevé	0204 1068 - 2012	Relevé	0204 1069 - 2012	Relevé	0204 1070 - 2012	Relevé	0204 1071 - 2012	Relevé	0204 1072 - 2012	Relevé	0204 1073 - 2012	Relevé	0204 1074 - 2012	Relevé	0204 1075 - 2012	Relevé	0204 1076 - 2012	Relevé	0204 1077 - 2012	Relevé	0204 1078 - 2012	Relevé	0204 1079 - 2012	Relevé	0204 1080 - 2012	Relevé	0204 1081 - 2012	Relevé	0204 1082 - 2012	Relevé	0204 1083 - 2012	Relevé	0204 1084 - 2012	Relevé	0204 1085 - 2012	Relevé	0204 1086 - 2012	Relevé	0204 1087 - 2012	Relevé	0204 1088 - 2012	Relevé	0204 1089 - 2012	Relevé	0204 1090 - 2012	Relevé	0204 1091 - 2012	Relevé	0204 1092 - 2012	Relevé	0204 1093 - 2012	Relevé	0204 1094 - 2012	Relevé	0204 1095 - 2012	Relevé	0204 1096 - 2012	Relevé	0204 1097 - 2012	Relevé	0204 1098 - 2012	Relevé	0204 1099 - 2012	Relevé	0204 1100 - 2012
Relevé	0204 1007 - 2012																																																																																																																																																																																													
Relevé	0204 1008 - 2012																																																																																																																																																																																													
Relevé	0204 1009 - 2012																																																																																																																																																																																													
Relevé	0204 1010 - 2012																																																																																																																																																																																													
Relevé	0204 1011 - 2012																																																																																																																																																																																													
Relevé	0204 1012 - 2012																																																																																																																																																																																													
Relevé	0204 1013 - 2012																																																																																																																																																																																													
Relevé	0204 1014 - 2012																																																																																																																																																																																													
Relevé	0204 1015 - 2012																																																																																																																																																																																													
Relevé	0204 1016 - 2012																																																																																																																																																																																													
Relevé	0204 1017 - 2012																																																																																																																																																																																													
Relevé	0204 1018 - 2012																																																																																																																																																																																													
Relevé	0204 1019 - 2012																																																																																																																																																																																													
Relevé	0204 1020 - 2012																																																																																																																																																																																													
Relevé	0204 1021 - 2012																																																																																																																																																																																													
Relevé	0204 1022 - 2012																																																																																																																																																																																													
Relevé	0204 1023 - 2012																																																																																																																																																																																													
Relevé	0204 1024 - 2012																																																																																																																																																																																													
Relevé	0204 1025 - 2012																																																																																																																																																																																													
Relevé	0204 1026 - 2012																																																																																																																																																																																													
Relevé	0204 1027 - 2012																																																																																																																																																																																													
Relevé	0204 1028 - 2012																																																																																																																																																																																													
Relevé	0204 1029 - 2012																																																																																																																																																																																													
Relevé	0204 1030 - 2012																																																																																																																																																																																													
Relevé	0204 1031 - 2012																																																																																																																																																																																													
Relevé	0204 1032 - 2012																																																																																																																																																																																													
Relevé	0204 1033 - 2012																																																																																																																																																																																													
Relevé	0204 1034 - 2012																																																																																																																																																																																													
Relevé	0204 1035 - 2012																																																																																																																																																																																													
Relevé	0204 1036 - 2012																																																																																																																																																																																													
Relevé	0204 1037 - 2012																																																																																																																																																																																													
Relevé	0204 1038 - 2012																																																																																																																																																																																													
Relevé	0204 1039 - 2012																																																																																																																																																																																													
Relevé	0204 1040 - 2012																																																																																																																																																																																													
Relevé	0204 1041 - 2012																																																																																																																																																																																													
Relevé	0204 1042 - 2012																																																																																																																																																																																													
Relevé	0204 1043 - 2012																																																																																																																																																																																													
Relevé	0204 1044 - 2012																																																																																																																																																																																													
Relevé	0204 1045 - 2012																																																																																																																																																																																													
Relevé	0204 1046 - 2012																																																																																																																																																																																													
Relevé	0204 1047 - 2012																																																																																																																																																																																													
Relevé	0204 1048 - 2012																																																																																																																																																																																													
Relevé	0204 1049 - 2012																																																																																																																																																																																													
Relevé	0204 1050 - 2012																																																																																																																																																																																													
Relevé	0204 1051 - 2012																																																																																																																																																																																													
Relevé	0204 1052 - 2012																																																																																																																																																																																													
Relevé	0204 1053 - 2012																																																																																																																																																																																													
Relevé	0204 1054 - 2012																																																																																																																																																																																													
Relevé	0204 1055 - 2012																																																																																																																																																																																													
Relevé	0204 1056 - 2012																																																																																																																																																																																													
Relevé	0204 1057 - 2012																																																																																																																																																																																													
Relevé	0204 1058 - 2012																																																																																																																																																																																													
Relevé	0204 1059 - 2012																																																																																																																																																																																													
Relevé	0204 1060 - 2012																																																																																																																																																																																													
Relevé	0204 1061 - 2012																																																																																																																																																																																													
Relevé	0204 1062 - 2012																																																																																																																																																																																													
Relevé	0204 1063 - 2012																																																																																																																																																																																													
Relevé	0204 1064 - 2012																																																																																																																																																																																													
Relevé	0204 1065 - 2012																																																																																																																																																																																													
Relevé	0204 1066 - 2012																																																																																																																																																																																													
Relevé	0204 1067 - 2012																																																																																																																																																																																													
Relevé	0204 1068 - 2012																																																																																																																																																																																													
Relevé	0204 1069 - 2012																																																																																																																																																																																													
Relevé	0204 1070 - 2012																																																																																																																																																																																													
Relevé	0204 1071 - 2012																																																																																																																																																																																													
Relevé	0204 1072 - 2012																																																																																																																																																																																													
Relevé	0204 1073 - 2012																																																																																																																																																																																													
Relevé	0204 1074 - 2012																																																																																																																																																																																													
Relevé	0204 1075 - 2012																																																																																																																																																																																													
Relevé	0204 1076 - 2012																																																																																																																																																																																													
Relevé	0204 1077 - 2012																																																																																																																																																																																													
Relevé	0204 1078 - 2012																																																																																																																																																																																													
Relevé	0204 1079 - 2012																																																																																																																																																																																													
Relevé	0204 1080 - 2012																																																																																																																																																																																													
Relevé	0204 1081 - 2012																																																																																																																																																																																													
Relevé	0204 1082 - 2012																																																																																																																																																																																													
Relevé	0204 1083 - 2012																																																																																																																																																																																													
Relevé	0204 1084 - 2012																																																																																																																																																																																													
Relevé	0204 1085 - 2012																																																																																																																																																																																													
Relevé	0204 1086 - 2012																																																																																																																																																																																													
Relevé	0204 1087 - 2012																																																																																																																																																																																													
Relevé	0204 1088 - 2012																																																																																																																																																																																													
Relevé	0204 1089 - 2012																																																																																																																																																																																													
Relevé	0204 1090 - 2012																																																																																																																																																																																													
Relevé	0204 1091 - 2012																																																																																																																																																																																													
Relevé	0204 1092 - 2012																																																																																																																																																																																													
Relevé	0204 1093 - 2012																																																																																																																																																																																													
Relevé	0204 1094 - 2012																																																																																																																																																																																													
Relevé	0204 1095 - 2012																																																																																																																																																																																													
Relevé	0204 1096 - 2012																																																																																																																																																																																													
Relevé	0204 1097 - 2012																																																																																																																																																																																													
Relevé	0204 1098 - 2012																																																																																																																																																																																													
Relevé	0204 1099 - 2012																																																																																																																																																																																													
Relevé	0204 1100 - 2012																																																																																																																																																																																													
Objet	Porte levante coulissante anti-effraction																																																																																																																																																																																													
Objet	Porte levante coulissante																																																																																																																																																																																													
Dimensions	1367 mm x 2590 mm																																																																																																																																																																																													
Matériau	Aluminium, système WICSLIDE 140																																																																																																																																																																																													
Utilisation	Clôture extérieure de l'ouvrage																																																																																																																																																																																													
Type d'ouvrant	Coulissant à levage, schéma A																																																																																																																																																																																													
Usage	Vitrage double isolant, classe P4A selon EN 556 WICSTAR HS303-HS403 avec chromé 6930112, guidages à glissement en haut, 2 verrouillages à tête chamfronée, cylindre poignée 6920241, protection contre le perçage avec HS safe et mécanisme condamnable à clé avec poignée levier 6930241 Selon notice de montage du 18/07/2012 de la société Hydro Building Systems GmbH																																																																																																																																																																																													
Projetant																																																																																																																																																																																														
Projetant																																																																																																																																																																																														
Projetant																																																																																																																																																																																														
Résistance à l'effraction Classe RC 2 / RC 2 N																																																																																																																																																																																														
IR Rosenheim 16.11.2012 Responsable technique ingénieur de projet Responsable de construction																																																																																																																																																																																														
Classe de sécurité "Cat. 1" (PH) Laboratoire Irrosheim																																																																																																																																																																																														

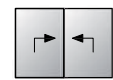

Cross-section through threshold

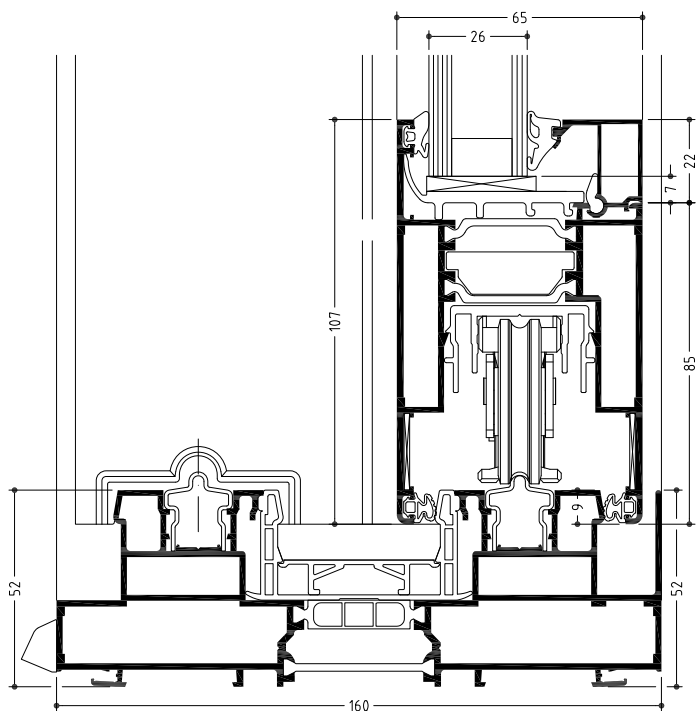

1/2 SCALE

- Insulation improved by 40 mm thermal break
- Plastic thermal shield and gutter profile
- Stainless steel track for longevity and resistance to heavy loads
- Maximum load per leaf 400 Kg

Enhanced thermal and acoustic insulation

Thermal foam in sash frame rebate
PVC cover insert



Non-reinforced hooking zone

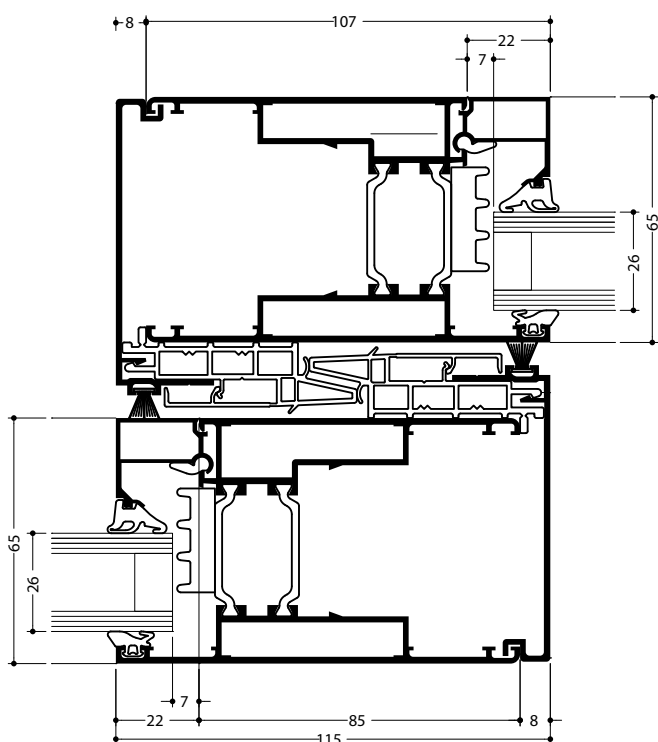

1/2 SCALE

- Sash frame thermal break 30 mm
- Plastic hooking profile with coextruded gaskets
- Concealed screws

Sash fixation

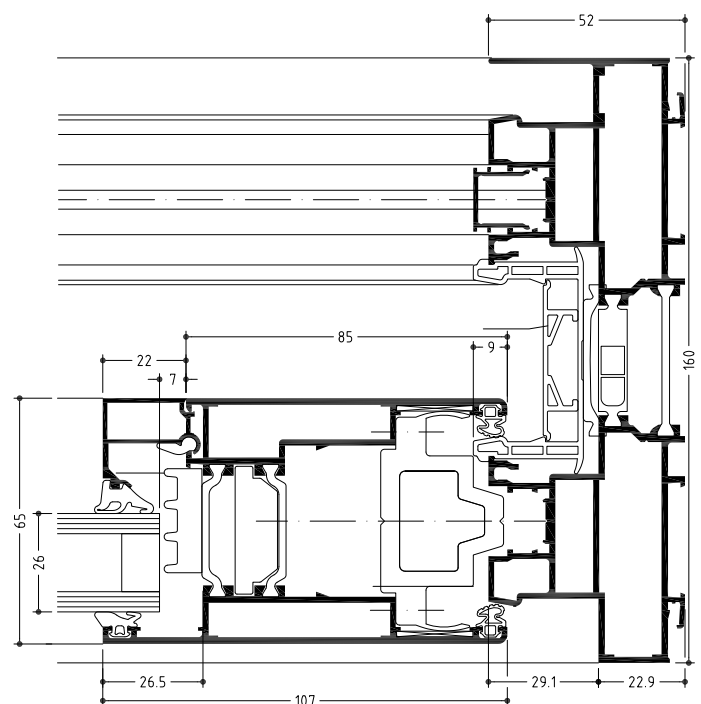

1/2 SCALE

- Symmetrical visible profiles
- Screw-fitted mounting parts at bottom and sides

WICSLIDE 160



Monorail with fixed glazing

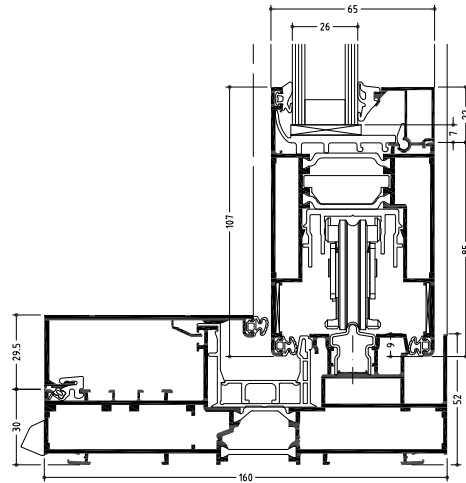

1/3 SCALE

- Maximum glazing thickness 47 mm
- Drainage via plastic thermal shield and gutter profile
- Ribbed aluminium cover profiles at the bottom

Central hooking zone and sash

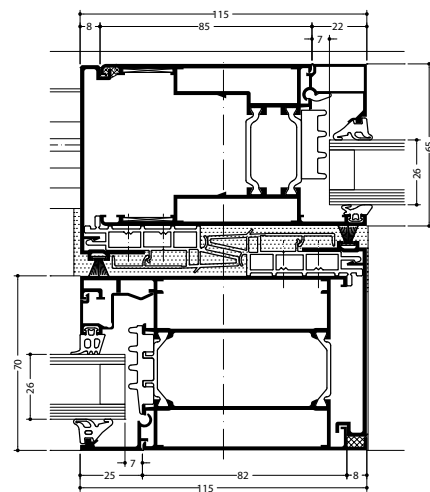

1/3 SCALE

- Plastic hooking profile with coextruded gaskets
- Straight cut mullion assembly
- Exterior installation of the glazing



Burglar resistance

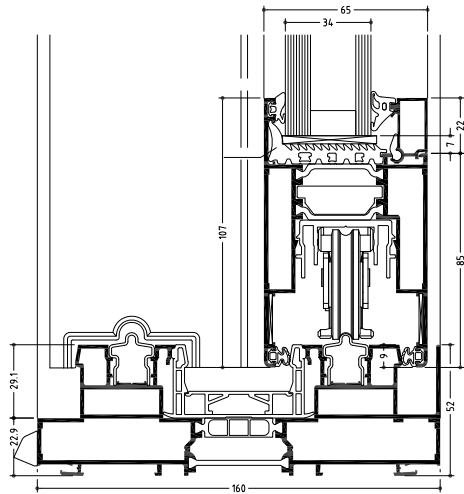

1/3 SCALE

- Infill safeguard installed in rebate
- Special fittings
- Anti-drill lock plate

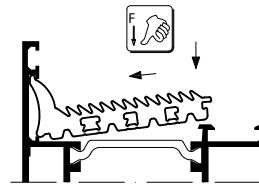
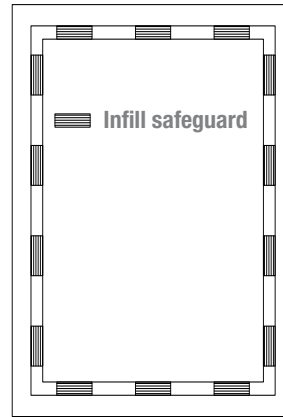

1/2 SCALE

High thermal insulation $U_w = 1.1 \text{ W/m}^2\text{K}$

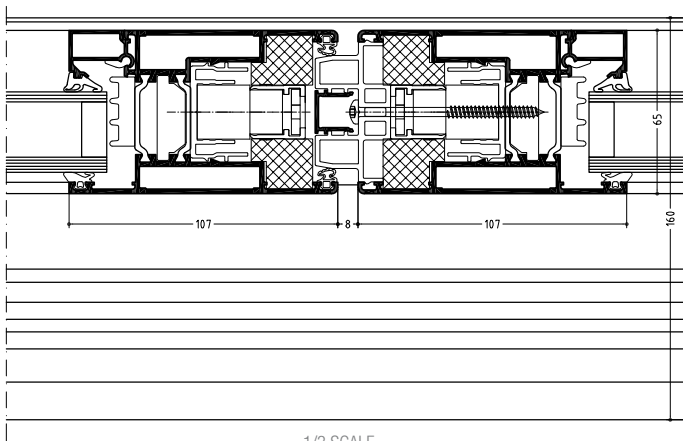

1/3 SCALE

- Central sash joint schemes C and F
- Sash joint insulation profile
- Insertion of insulation profiles possible

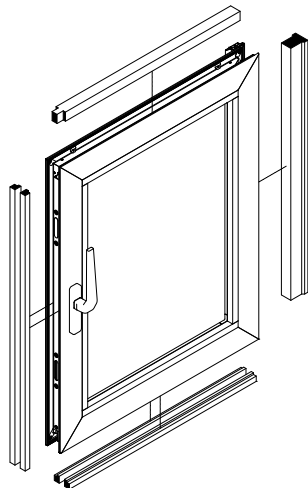

- Insertion of insulating profiles around the sash



2 | Via Tosatto - Architect: Claudio Biancon, Italy

WICSLIDE 160

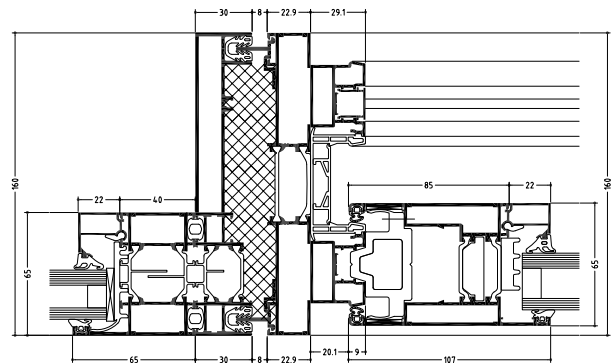

1/4 SCALE

Connection with WICLINE 65/75 window and the WICSTYLE 65/75 door

Coupling profiles permits WICLINE 65/75 series, WICSTYLE 65/75, and WICSLIDE 160 fixed frames to be connected together vertically (mullion).

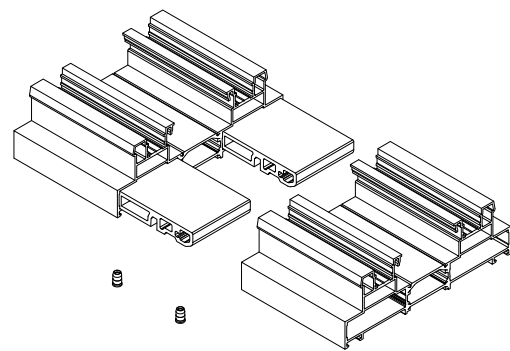

Frame profile joint

Connecting and joining straight cut frames > 6.50 m in length (refer to our workshop manuals)

Installing internal insulation

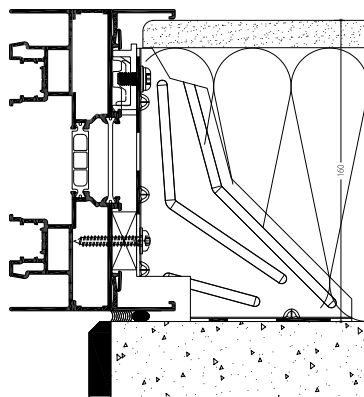

1/4 SCALE

160 mm glazing unit

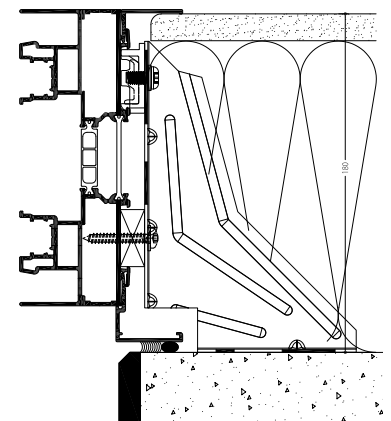

1/4 SCALE

180 mm glazing unit



Closure systems



Handles: A complete range of handles (with or without cylinder) caters for all applications.



Mushroom locking point: Running face plate incorporated into the sash, up to 5 locking points, additional accessories offer up to RC2 burglar resistance.



Flush-mounted strike plates: Fully incorporated into the fixed frame and without sharp edges, precluding the risk of catching clothing.

Sash accessories



Weather tightness (top): The patented WICONA system ensures continued weather tightness in all positions of the sash.



Weather tightness (bottom): A system of sealing parts assures perfect sealing with the stainless steel track.

Lift-and-slide system



Rollers with integrated brushes: The 44 mm diameter rolling system with the cleaning brush ensures smooth, silent and long-lasting operation.

Equipment

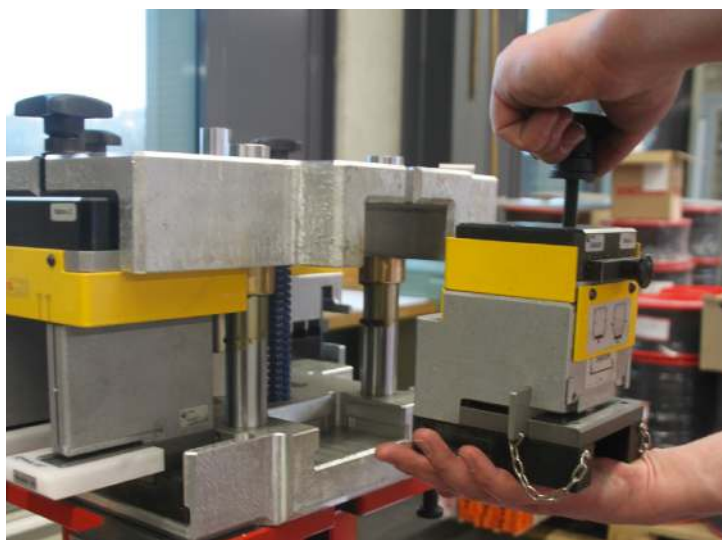

Reliability, productivity and durability of WICPRO equipment.

WICPRO®

Tools, punches and casings adapted for production.

The tools, punches and casings required for the fabrication of glazing systems for the WICONA range are customized for the system.

Perfectly adapted to our range of products, WICPRO tools offer a simple manufacturing process to suit your needs and ensure efficient and optimal production.

WICPRO offers a choice of punching machines and drilling jigs for customized products, etc.

WICPRO optimises tool related costs.

Opening types

Lifting sliding door / window
with fixed glazing

Double track

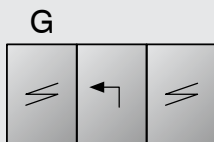
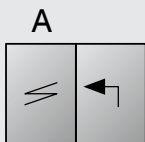

Triple track



Lifting sliding door / window

Double track

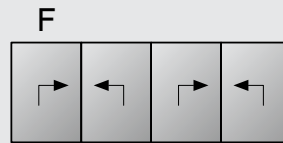
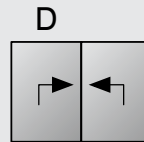

Triple track



WICONA®

SBS Asia, Africa, Americas

270 rue Léon Joulin - BP 63709
31037 Toulouse cedex 01 France
Téléphone +33 5 61 31 26 26
www.wicona-int.com

Middle East

P.O. Box 263237
Jebel Ali Free Zone
LOB 17, Office 313/314
Dubai United Arab Emirates
T: +971 4 887 00 96

www.wicona-int.com

www.WICONAfinder.com



www.wicona.com